

深圳触觉智能科技有限公司

SPECIFICATION FOR LCD Module JY101FHQ-40D

MODULE:	JY101FHQ-40D
CUSTOMER:	

FCX	INITIAL	DATE
PREPARED BY		2021-03-12
CHECKED BY		2021-03-12
APPROVED BY		2021-03-12

CUSTOMER	INITIAL	DATE
APPROVED BY		

REVISION STATUS

Version	Revise Date	Page	Content	Modified by
V1.0	2021-03-12	-	First Issued.	

--	--	--	--	--

TABLE OF CONTENTS

1. General Description
2. Mechanical Characteristics
3. Pin Description
4. Electrical Characteristics
5. Optical Characteristics
6. Quality Specifications
7. Reliability
8. Handling Precaution

--	--	--	--	--

1. General Description

* DESCRIPTION

This is a color active matrix TFT (Thin Film Transistor) LCD (liquid crystal display) that uses amorphous silicon TFT as a switching device. This model is composed of a Transmissive type TFT-LCD Panel, driver circuit, back-light unit. The resolution of a 10.1" TFT-LCD contains 1200 x 1920 pixels, and can display up to 16.7M colors.

* Features

- Low Input Voltage: IOVCC: 1.65~3.3V;VCC: 2.5~3.3V
- Display Colors of TFT LCD: 16.7M colors
- Interface: MIPI
- Internal Power Supply Circuit.

General Information Items	Specification	Unit	Note
	Main Panel		
Display area(AA)	135.36(H) x 216.576(V)	mm	-
Driver element	a-Si TFT active matrix	-	-
Display colors	16.7M	colors	-
Number of pixels	1200(RGB) *1920	dots	-
Pixel arrangement	RGB vertical stripe	-	-
Pixel pitch	0.1128(H) ×0.1128(V)	mm	-
Viewing angle	FREE	o'clock	-
Drive IC	OTA7290B	-	-
Display mode	Normally Black	-	-
Operating temperature	-10 ~ +60	°C	-
Storage temperature	-20 ~ +70	°C	-

Mechanical Information

Item		Min.	Typ.	Max.	Unit	Note
Module size	Horizontal(H)	-	142.9	-	mm	±0.2
	Vertical(V)	-	228.5	-	mm	±0.2
	Depth(D)	-	2.3	-	mm	±0.2
Weight		-	TBD	-	g	-

2. MECHANICAL SPECIFICATION

--	--	--	--	--

All Pages Of This Edition Approved

Signature: _____

Date: _____



REV.	DESCRIPTION	REVISER	DATE
V0	NEW	LONG	2020.09.22
V1	Modify the Component area and add conductive tape	LONG	2020.09.24

Pin description

1	NC
2	VDD
3	VDD
4	GND
5	RESET
6	NC
7	GND
8	MIPI_D0-
9	MIPI_D0+
10	GND
11	MIPI_D1-
12	MIPI_D1+
13	GND
14	MIPI_CLK-
15	MIPI_CLK+
16	GND
17	MIPI_D2-
18	MIPI_D2+
19	GND
20	MIPI_D3-
21	MIPI_D3+
22	GND
23	NC
24	NC
25	GND
26	NC
27	LED_PWM
28	NC
29	NC
30	GND
31	LED-
32	LED-
33	NC
34	NC
35	NC
36	NC
37	NC
38	NC
39	LED+
40	LED+

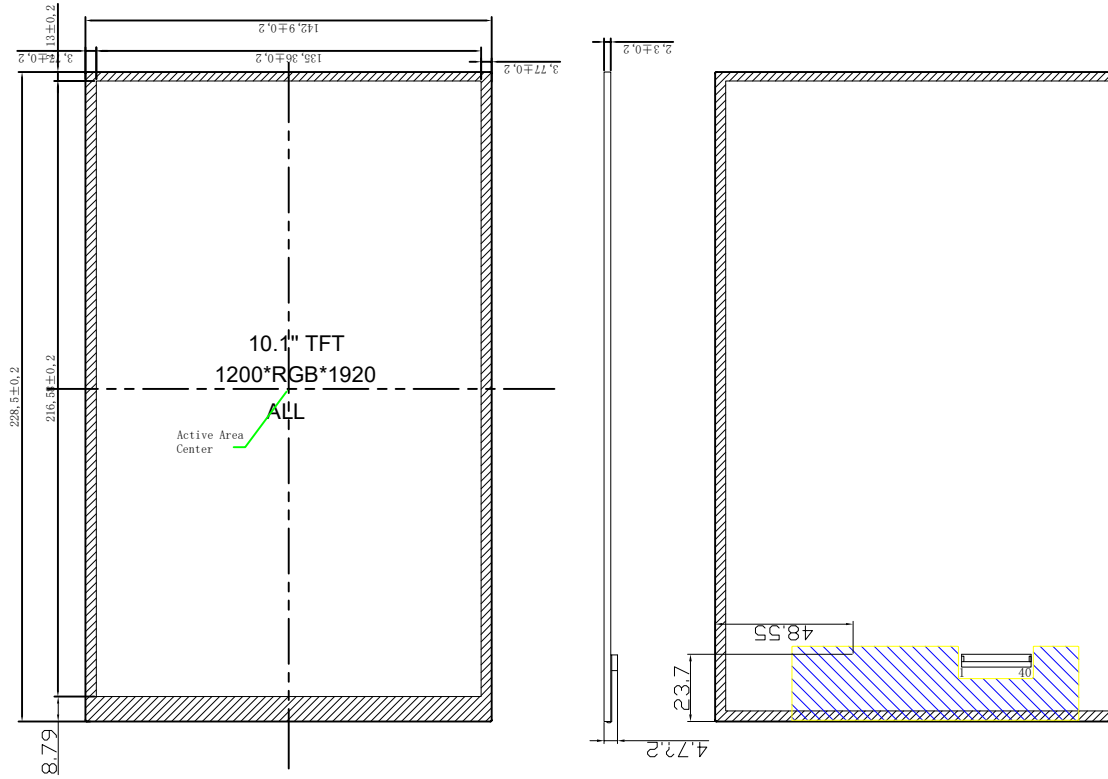

Specification:

- 1). Viewing angle: FULL VIEW
- 2). Display mode: TFT/Transmissive/Normal Black
- 3). Operating temp.: -20° C~+60° C
Storage temp.: -20° C~+70° C
- 4). Backlight: 32 chip White LED , In Series, If=160mA,
- 5). Dimensions with mark "*" are important, with mark "(" are referenced
- 6). According to the RoHS

LED电路图

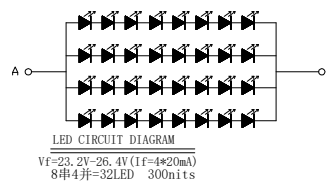

深圳触觉智能科技有限公司

Unspecified Tolerance:	±0.20	UNITS: mm	DATE:	MODEL NUMBER :		SHEET:	1 Of 1
DESIGN BY:				JY101FHQ-40D		DRAWING DESCRITUON:	LCM
CHECKED BY:					PROJECTION		
APPROVED BY:							

4. ELECTRICAL CHARACTERISTICS

4.1 ABSOLUTE MAXIMUM RATINGS

Item	Symbol	Values		Unit	Remark
		Min	Max.		
Supply Voltage for Logic circuit	VDDIO	1.7	3.0	V	
Supply Voltage for analog circuit	Vcc	3.0	3.6	V	

4.2 DC ELECTRICAL CHARACTERISTICS

4.2.1 POWER SPECIFICATION

INPUT POWER SPECIFICATIONS ARE AS FOLLOWS:

THE POWER SPECIFICATION ARE MEASURED UNDER 25°C AND FRAME FREQUENCY UNDER 60HZ

Typical Operating Conditions (Ta=25°C)

Item	Parameter	Values			Unit	Remark
		Min	Typ	Max.		
VCI	Vcc	3.0	3.3	3.6	V	
VDD3	Iovcc	1.7	1.8	3.0	V	
TFT Gate ON Voltage	Pixel turn on voltage	20.5	21	21.5	V	
TFT Gate OFF Voltage	Pixel turn off voltage	-7.5	-7	-6.5	V	
VSP	Negative AVEE voltage	4.8	5	6	V	
VSN	Positive AVDD voltage	-6	-5	-4.8	V	

4.2.2 BACKLIGHT UNIT (GND=0V)

Item	Symbol	Values			Unit	Remark
		Min	Typ	Max.		
Forward supply Voltage	Vf	23.2	24.8	26.4	V	
Forward supply Current	If	-	80	-	mA	
LCM Luminance	Lv	300	320	-	cd/m2	Ib=80mA
Uniformity	/	75	80		%	-

5. OPTICAL CHARACTERISTICS

Item	Symbol	Conditions	Specifications			Unit	Note
			Min.	Typ.	Max.		
Transmittance (w/o APCF)	T%	Viewing normal angle $\theta_x = \theta_y = 0^\circ$	3.53%	4.04%		%	All left side data are based on INX's following condition – 1.LC : AAS . 2.CF : CG 70% CF. 3.Light Source : INX LED BLU. 4.Polarizer : CF:CMT1794FCUHC3-6 TFT: CMT1794FCUHC3-6 5.Machine : DMS 803, (ConoScope for View Angle). 6. VLC dark ≤ 0.3 V, VLC white ≥ 4.1 V 7.Back light structure: Diffuser+BEF+BEF+ Diffuse
Contrast Ratio	CR		800	1000		--	
Response Time	$T_{on} + T_{off}$			25		ms	
Viewing Angle	Hor.	θ_{x+}	80	85		deg.	
		θ_{x-}	80	85			
	Ver.	θ_{y+}	80	85			
		θ_{y-}	80	85			
CF only Color Chromaticity (CIE 1931)	Red	Rx	0.631	0.651	0.671	-	Under C light Simulation
		Ry	0.311	0.331	0.351	-	
	Green	Gx	0.255	0.275	0.295	-	
		Gy	0.54	0.56	0.58	-	
	Blue	Bx	0.12	0.14	0.16	-	
		By	0.075	0.095	0.115	-	
	White	Wx	0.28	0.3	0.32	-	
		Wy	0.305	0.325	0.345	-	
	Color Gamut			65		%	

*Note (1) Definition of Contrast Ratio (CR):

The contrast ratio can be calculated by the following expression.

$$\text{Contrast Ratio (CR)} = L_{63} / L_0$$

L63: Luminance of gray level 63

L 0: Luminance of gray level 0

$$\text{CR} = \text{CR} (5)$$

CR (X) is corresponding to the Contrast Ratio of the point X at Figure in Note (5).

--	--	--	--	--

*Note (2) Definition of Response Time (T_{on} , T_{off}):

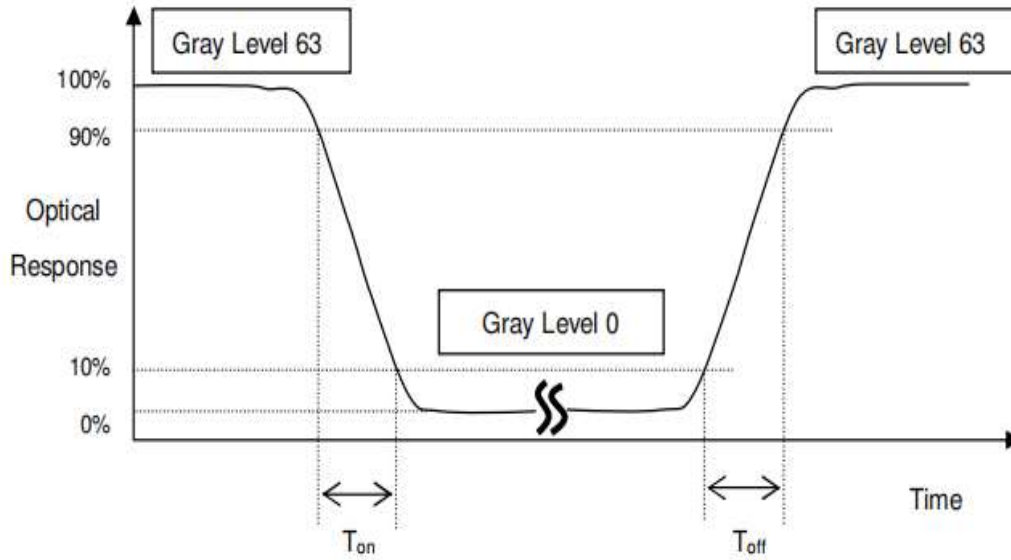

*Note (3) Definition of Viewing Angle

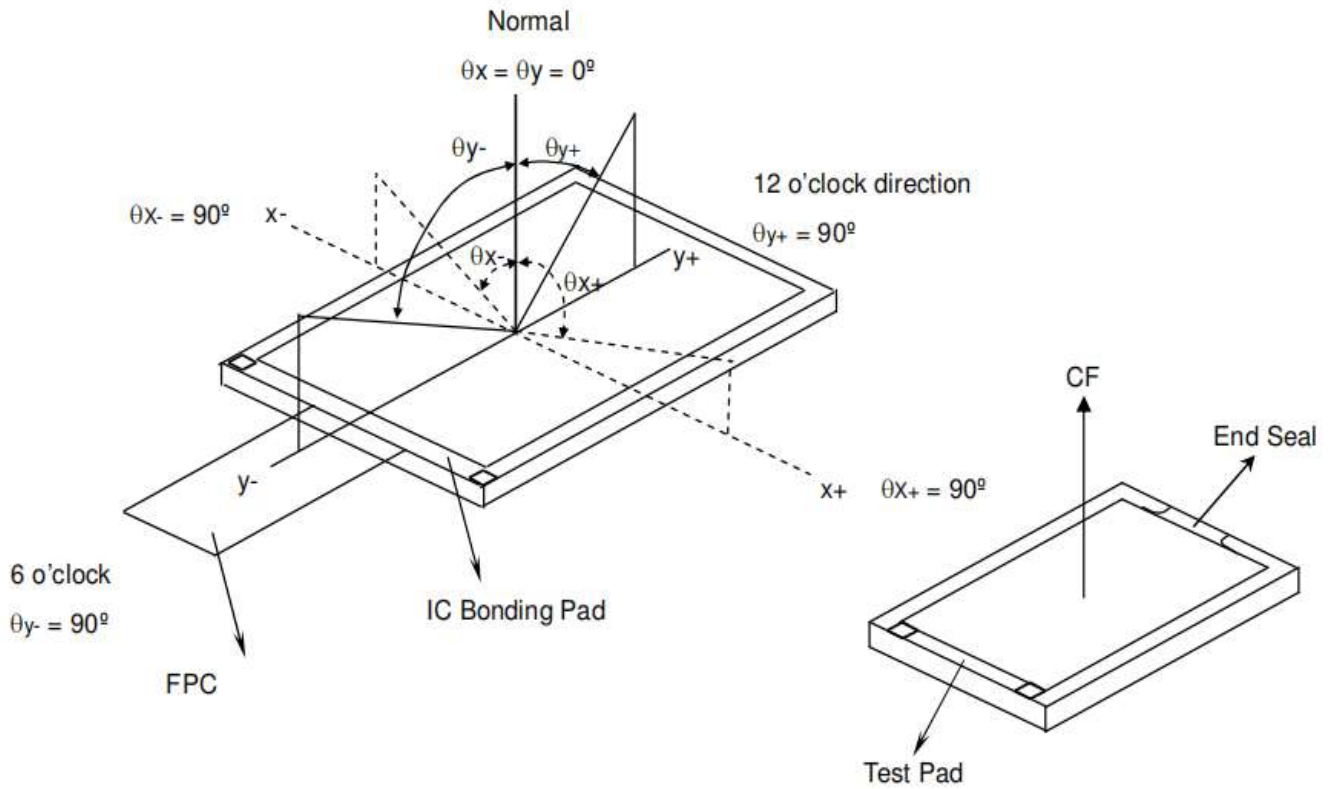

*Note (4) Measurement Set-Up:

The LCD module should be stabilized at a given temperature for 20 minutes to avoid abrupt temperature change during measuring. In order to stabilize the luminance, the measurement should be executed after lighting Backlight for 20 minutes in a windless room.

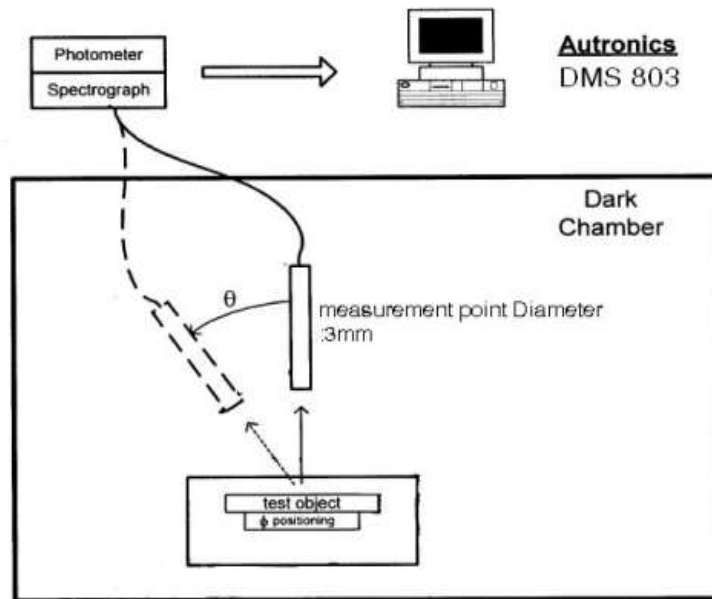

*Note (5)

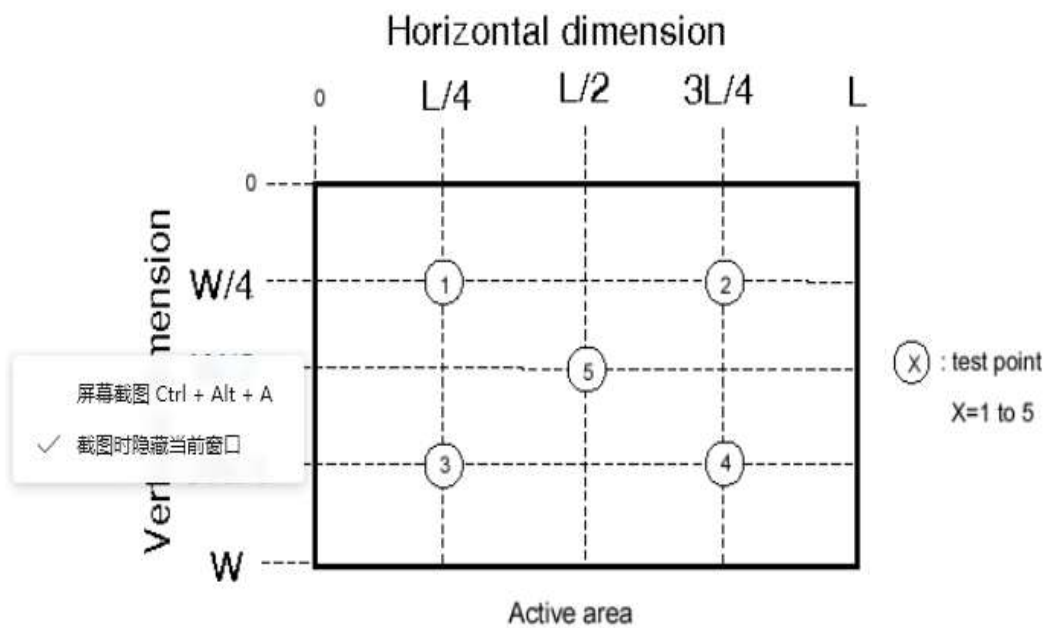

屏幕截图 Ctrl + Alt + A
 截图时隐藏当前窗口

6. QUALITY SPECIFICATIONS

6.1 INSPECTION CONDITION

- (1) Inspect under 300~500Lux fluorescent light, leaving 30~35cm between panels and eyes, and between panels and lights.
- (2) Inspection condition is $23\pm 5^{\circ}\text{C}$, $50\pm 20\%\text{RH}$ maximum.

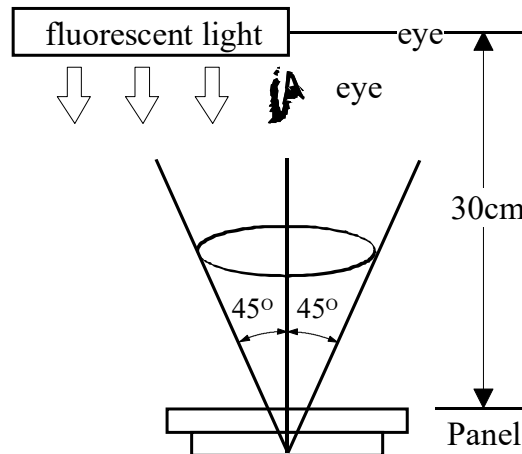

6.2 DEFINITION OF AREA

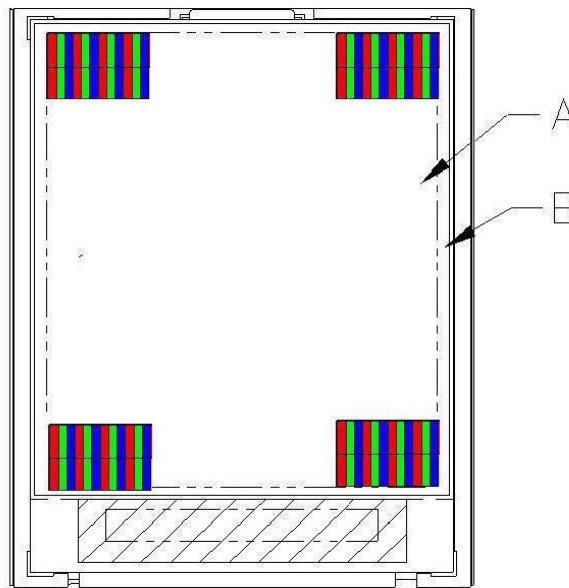

A Area : Viewing area.

B Area : Out of viewing area.(outside viewing area)

6.3 INSPECTION SPECIFICATION

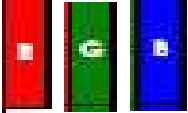
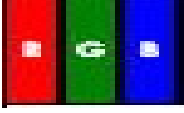
NO	Item	Acceptable specification	Judgment Criterion
1	Electrical Testing	<p>1-1 sub pixel classification</p> <ul style="list-style-type: none"> ● Sub Pixel: Number of sub pixel doesn't exceed one dot. <div style="text-align: center;">  <p>Sub Pixel (Dot)</p> </div> <p>a> Dark dot ----one Allowed b> Bright dot ---- one Allowed</p> <ul style="list-style-type: none"> ● Pixel : Three dots link together doesn't exceed ones <div style="text-align: center;">  <p>Pixel</p> </div> <p>1-2 Leakage to light</p> <ul style="list-style-type: none"> ● Leakage to light be not allowed. <p>1-3 Picture to shake</p> <ul style="list-style-type: none"> ● Picture had shake, twinkle and noise etc. instable of defect that be not allowed. <p>1-4 Function</p> <ul style="list-style-type: none"> ● No display or No function. ● Source Line, Gate Line. ● Contrast Ratio ● Current consumption exceeds product specifications. ● Display malfunction. 	<p>$N \leq 1$</p> <p>$N \leq 0$</p> <p>$N=0$</p> <p>$N=0$</p> <p>$N=0$</p>
2	Mechanical Dimension	<p>2-1 Mechanical Dimension exceeds product specifications.</p> <p>2-2 Out of frame and boss of plastic changed shape that be not allowed.</p>	<p>$N=0$</p>

NO	Item	Acceptable specification	Judgment Criterion
----	------	--------------------------	--------------------

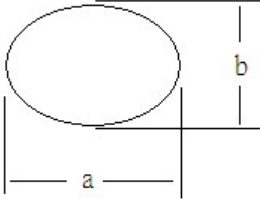
3	Cosmetic Inspection	3-1 Blemish: Line shapes of defect			
		Length	Width	Acceptable number	Mini. space
		---	$W \leq 0.03$	Ignore	5 m m
$L \leq 2.5$	$0.03 < W \leq 0.05$	3			
$L \leq 2.5$	$0.05 < W \leq 0.1$	2			
		--	$W > 0.1$	Not allowed	---
		<p>L: length(mm) W: width(mm)</p> 			
		3-2 Blemish: dot shapes of defect.			
		Dimension	Acceptable number	Mini. Space	
		$\Phi \leq 0.10$	Ignore	---	
		$0.10 < \Phi \leq 0.25$	2	10 m m	
		$0.25 < \Phi \leq 0.3$	1		
		$\Phi > 0.3$	0	---	
		3-3 Polarizer Bubble			
		Dimension	Acceptable number	Mini. Space	
		$\Phi \leq 0.20$	Ignore	---	
		$0.20 < \Phi \leq 0.30$	2	15 m m	
		$\Phi > 0.30$	0	---	
		Foreign Substances			
				$\Phi = (a+b)/2$	

NO	Item	Acceptable specification	Judgment Criterion
----	------	--------------------------	--------------------

3	Cosmetic Inspection	3-4 Scratch <ul style="list-style-type: none"> ● Sensate scratch not allowed. ● Impassive scratch as below. 			Unit:mm	
		Length	Width	Acceptable number		Mini. space
		-----	$W \leq 0.03$	Ignore		5 m m
		$L \leq 2.5$	$0.03 < W \leq 0.05$	3		
		$L \leq 2.5$	$0.05 < W \leq 0.1$	2		
		----	$0.1 < W$	Not allowed		---
		$L > 2.5$	----	Not allowed		
4	Package	4-1 Mixed product types 4-2 Shipping q'ty should be the same as "shipping notice form" q'ty. 4-3 Outer box can't broken.			N=0	

7. RELIABILITY

Test Item	Test Condition
High Temperature Operation	60°C for 24 hours
Low Temperature Operation	-10°C for 24 hours
High Temperature Storage	70°C for 24 hours
Low Temperature Storage	-20°C for 24 hours
High Temperature Operation Humidity Operation	50°C, 90%RH for 48 hours
Thermal Shock	-10° storage one hour, rise to 60° within 15s, high temperature one hour, drop to 30° within 15s, circulate 10 repeatedly
Vibration Test (No Operation)	Frequency: 10-55Hz Amplitude:1.0mm Sweep Time: 11min Test Period: 6 Cycles for each direction of X, Y, Z
Static electricity test	Touch 6KV, air touch 8KV

8. HANDLING PRECAUTION

8.1 SAFETY

- (1) Do not swallow any liquid crystal, even if there is no proof that liquid crystal is poisonous.
- (2) If the LCD panel breaks, be careful not to get liquid crystal to touch your skin.
- (3) If skin is exposed to liquid crystal, wash the area thoroughly with alcohol or soap.

8.2 STORAGE CONDITIONS

- (1) Store the panel or module in a dark place where the temperature is $23\pm 5^{\circ}\text{C}$ and the humidity is below $50\pm 20\% \text{RH}$.
- (2) Store in anti-static electricity container.
- (3) Store in clean environment, free from dust, active gas, and solvent.
- (4) Do not place the module near organics solvents or corrosive gases.
- (5) Do not crush, shake, or jolt the module.

8.3 HANDLING PRECAUTIONS

- (1) Avoid static electricity which can damage the CMOS LSI.
- (2) The polarizing plate of the display is very fragile. So, please handle it very carefully.
- (3) Do not give external shock.
- (4) Do not apply excessive force on the surface.
- (5) Do not wipe the polarizing plate with a dry cloth, as it may easily scratch the surface of plate.
- (6) Do not use ketonic solvent & Aromatic solvent, use with a soft cloth soaked with a cleaning naphtha solvent.
- (7) Do not operate it above the absolute maximum rating.
- (8) Do not remove the panel or frame from the module.

8.4 WARRANTY

The period is within twelve months since the date of shipping out under normal using and storage conditions.