

### Features

- 500-mA-Rated Collector Current(single output)
- High-Voltage Outputs:50V
- Output Clamp Diodes
- Inputs Compatible With Various Types of Logic
- Relay-Driver Applications

### General Description

The ULN2003 is high-voltage high-current Darlington transistor arrays each containing seven open collector common emitter pairs. Each pair is rated at 500mA. Suppression diodes are included for inductive load driving, the inputs and outputs are pinned in opposition to simplify board layout.

These devices are capable of driving a wide range of loads including solenoids, relays, DC motors, LED displays, filament lamps, thermal print-heads and high-power buffers.

The ULN2003 is available in both a small outline 16-pin package (DIP16, SOP16 ,SSOP16 and TSSOP16 ).

### Pin Assignments

(TOP VIEW)

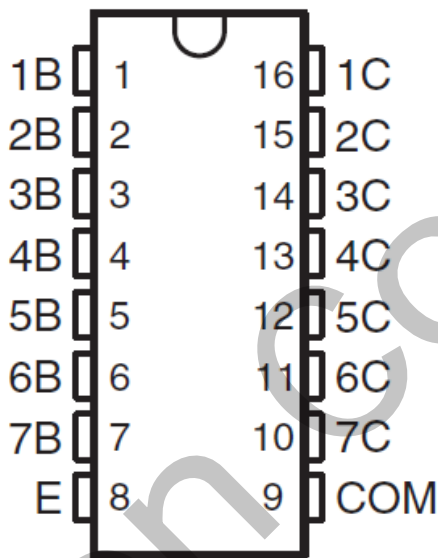

### Connection Diagram

LOGIC DIAGRAM

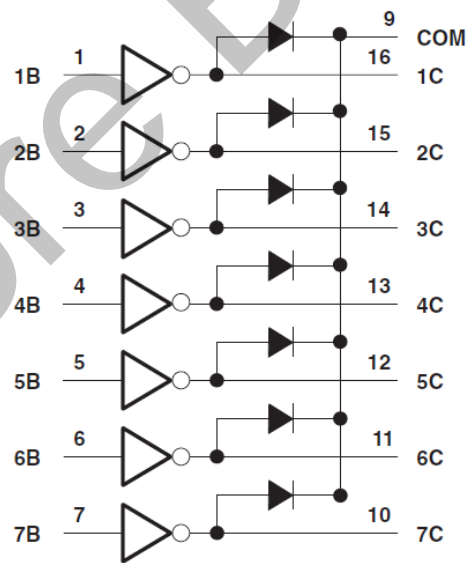

**Pin Descriptions**

Pin Number	Pin Name	Function
1	1B	Input pair1
2	2B	Input pair1
3	3B	Input pair1
4	4B	Input pair1
5	5B	Input pair1
6	6B	Input pair1
7	7B	Input pair1
8	E	Common Emitter (ground)
9	COM	Common Clamp Diodes
10	7C	Output pair7
11	6C	Output pair6
12	5C	Output pair5
13	4C	Output pair4
14	3C	Output pair3
15	2C	Output pair2
16	1C	Output pair1

**Functional Block Diagram**

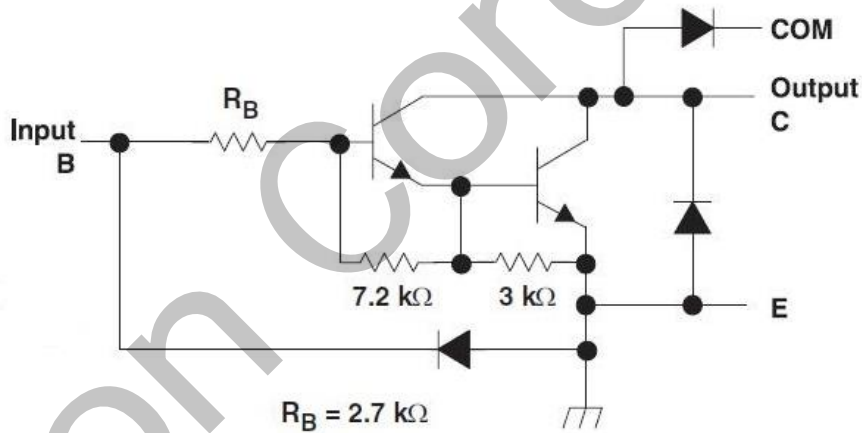

Note: All resistor values shown are nominal.

The collector-emitter diode is a parasitic structure and should not be used to conduct current. If the collector(s) go below ground an external Schottky diode should be added to clamp negative undershoots.

**Absolute Maximum Ratings <sup>(1)</sup>**

At 25°C free-air temperature (unless otherwise noted)

Symbol	Parameter		Min	Max	Unit
V <sub>CC</sub>	Collector to emitter voltage			50	V
V <sub>R</sub>	Clamp diode reverse voltage(2)			50	V
V <sub>I</sub>	Input voltage(2)			30	V
I <sub>CP</sub>	Peak collector current	See typical characteristics		500	mA
I <sub>OK</sub>	Output clamp current			500	mA
I <sub>TE</sub>	Total emitter-terminal current			-2.5	A
T <sub>A</sub>	Operating free-air temperature range	ULN2003	-40	+105	°C
θ <sub>JA</sub>	Thermal Resistance Junction-to-Ambient(3)			63	°C/W
θ <sub>JC</sub>	Thermal Resistance Junction-to-Case(4)			12	
T <sub>J</sub>	Operating virtual junction temperature			+150	°C
T <sub>STG</sub>	Storage temperature range		-65	+150	°C
ESD	Human Body Mode		--	3000	V

- (1) Stresses beyond those listed under "absolute maximum ratings" may cause permanent damage to the device. These are stress ratings only, and functional operation of the device at these or any other conditions beyond those indicated under "recommended operating conditions" is not implied. Exposure to absolute-maximum-rated conditions for extended periods may affect device reliability.
- (2) All voltage values are with respect to the emitter/substrate terminal E, unless otherwise noted.
- (3) Maximum power dissipation is a function of T<sub>J(max)</sub>, θ<sub>JA</sub>, and T<sub>A</sub>. The maximum allowable power dissipation at any allowable ambient temperature is  $PD = (T_J(max) - T_A)/\theta_{JA}$ . Operating at the absolute maximum T<sub>J</sub> of 150°C can affect reliability.
- (4) Maximum power dissipation is a function of T<sub>J(max)</sub>, θ<sub>JC</sub>, and T<sub>A</sub>. The maximum allowable power dissipation at any allowable ambient temperature is  $PD = (T_J(max) - T_A)/\theta_{JC}$ . Operating at the absolute maximum T<sub>J</sub> of 150°C can affect reliability.

**Recommended Operating Conditions**

Symbol	Parameter	Min	Max	Unit
V <sub>CC</sub>	Collector to Emitter voltage	-	50	V
T <sub>A</sub>	Operating Ambient Temperature	-40	+105	°C

**Electrical Characteristics (TA=+25°C, unless otherwise specified)**

Parameter		Test Figure	Test Conditions		TX2003A			Unit
					MIN	TYP	MAX	
V <sub>I(on)</sub>	On-state input voltage	Figure 6	VCE = 2 V	IC = 200 mA	--	--	2.4	V
				IC = 250 mA	--	--	2.7	
				IC = 300 mA	--	--	3	
V <sub>CE(sat)</sub>	Collector-emitter saturation voltage	Figure 5	II = 250 μA, IC = 100 mA	--	0.9	1.1	V	
			II = 350 μA, IC = 200 mA	--	1	1.3		
			II = 500 μA, IC = 350 mA	--	1.2	1.6		
I <sub>CEX</sub>	Collector cutoff current	Figure 1	VCE = 50 V, II = 0	--	--	50	μA	
		Figure 2	VCE = 50 V, TA = +105°C, II = 0	--	--	100		
V <sub>F</sub>	Clamp forward voltage	Figure 8	IF = 350 mA	--	1.7	2	V	
I <sub>I(off)</sub>	Off-state input current	Figure 3	VCE = 50 V, IC = 500 μA	50	65	--	μA	
II	Input current	Figure 4	VI = 3.85 V	--	0.93	1.35	mA	
			VI = 5 V	--	--	--		
			VI = 12 V	--	--	--		
IR	Clamp reverse current	Figure 7	VR = 50 V		--	--	50	μA
				TA = 70°C	--	--	100	
Ci	Input capacitance		VI = 0, f = 1 MHz	--	15	25	pF	

**Switching Characteristics (TA = +25°C, unless otherwise specified)**

Parameter		Test Conditions	ULN2003			UNIT
			MIN	TYP	MAX	
t <sub>PLH</sub>	Propagation delay time, low- to high-level output	See Figure 9		0.25	1	μs
t <sub>PHL</sub>	Propagation delay time, high- to low-level output	See Figure 9		0.25	1	μs
V <sub>OH</sub>	High-level output voltage after switching	VS = 50 V, IO = 300 mA, See Figure 9	VS-20			mV

Parameter Measurement Information

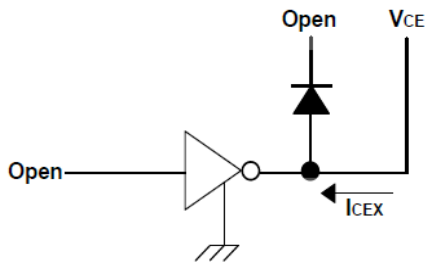

Fig.1 ICEX Test Circuit

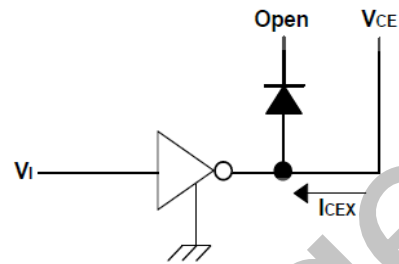

Fig.2 ICEX Test Circuit

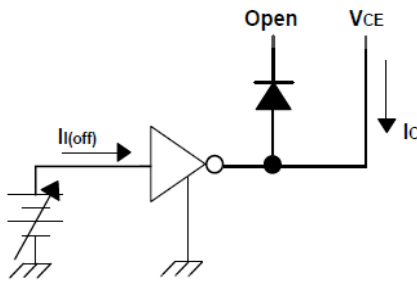

Fig.3 I(off) Test Circuit

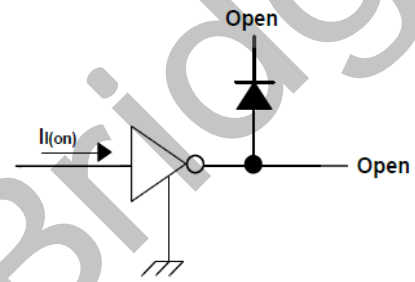

Fig.4 I(on) Test Circuit

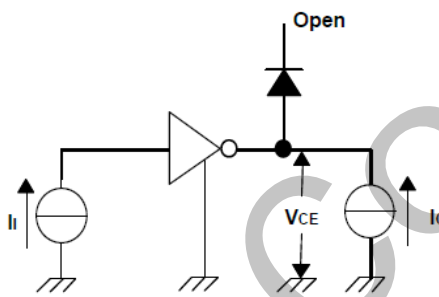

Fig. 5 hFE, VCE(sat) Test Circuit

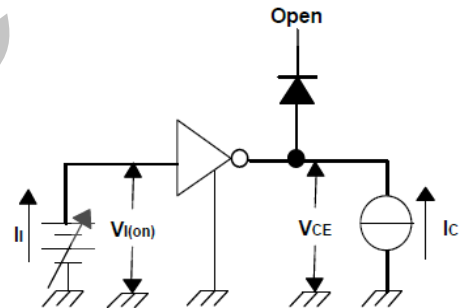

Fig. 6 V(on) Test Circuit

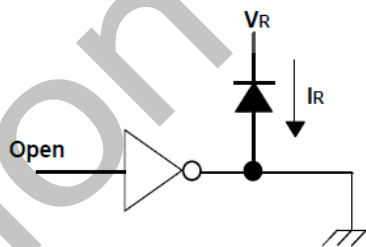

Fig. 7 IR Test Circuit

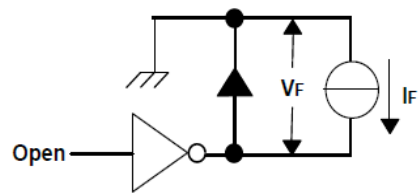

Fig. 8 VF Test Circuit

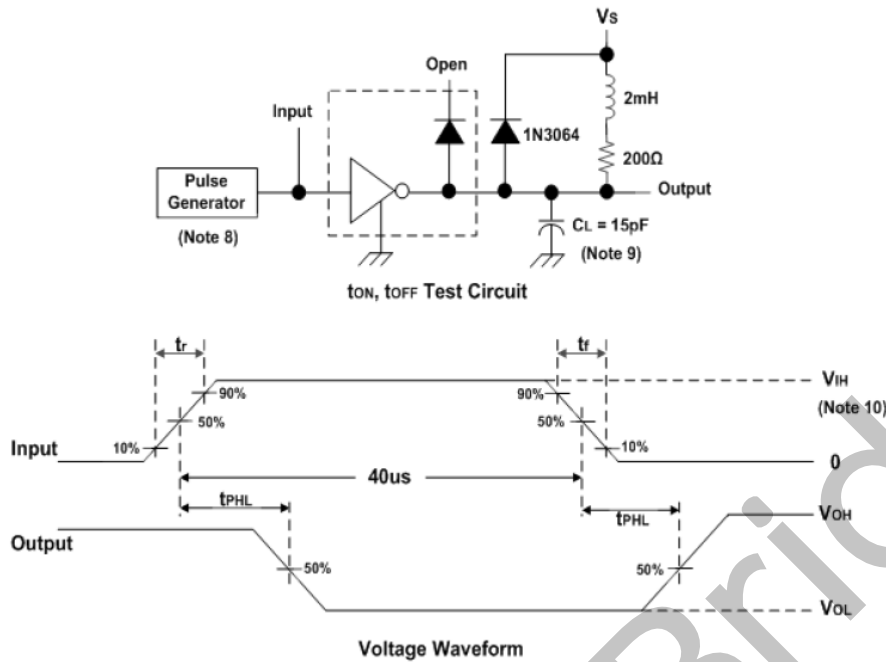

Fig. 9 Latch-Up Test Circuit and Voltage Waveform

Notes: 8. The pulse generator has the following characteristics:

Pulse Width=12.5Hz, output impedance 50Ω,  $t_r \leq 5ns$ ,  $t_f \leq 10ns$ .

9.  $C_L$  includes probe and jig capacitance.

10.  $V_{IH} = 3V$

### Marking Information

Marking	Designator	Description
ULN2003 SSSSWWX	ULN2003	Standard
	SSSS	Lot NO
	WW	Product Week
	X	Product Code

DIP16 Outline Dimensions

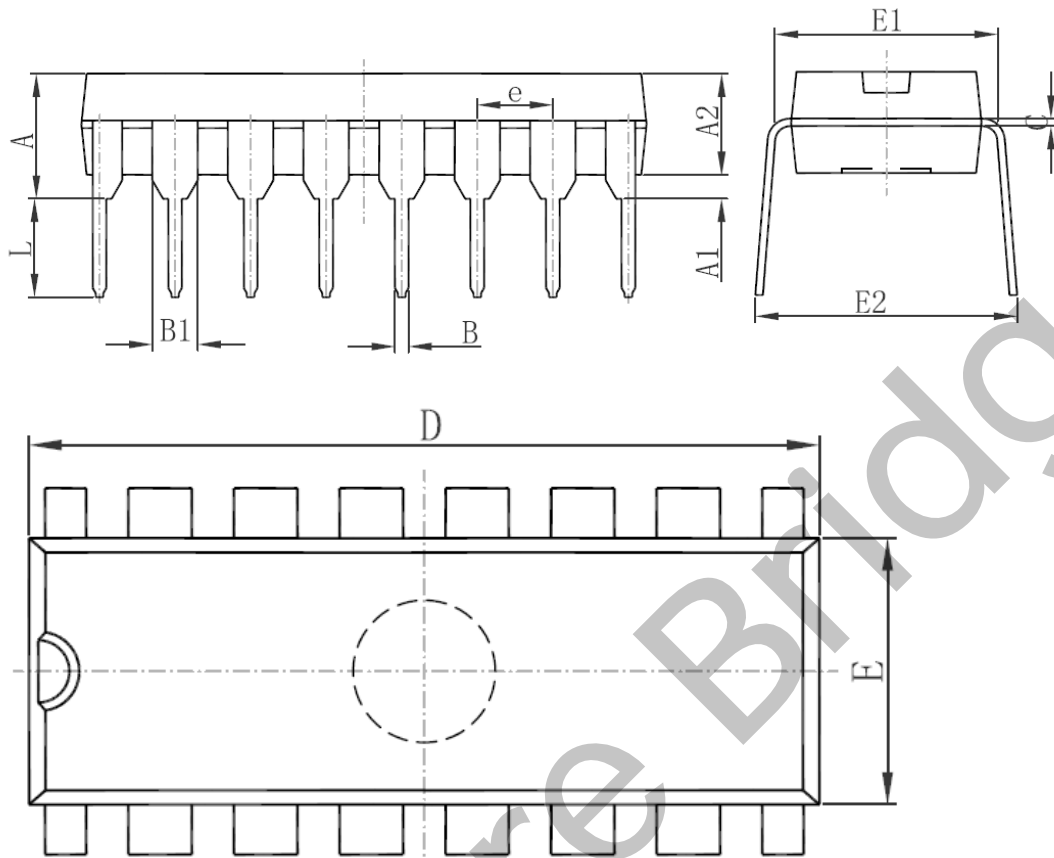

Symbol	Dimensions In Millimeters		Dimensions In Inches	
	Min	Max	Min	Max
A	3.710	4.310	0.146	0.170
A1	0.510		0.020	
A2	3.200	3.600	0.126	0.142
B	0.380	0.570	0.015	0.022
B1	1.524 (BSC)		0.060 (BSC)	
C	0.204	0.360	0.008	0.014
D	18.800	19.200	0.740	0.756
E	6.200	6.600	0.244	0.260
E1	7.320	7.920	0.288	0.312
e	2.540 (BSC)		0.100 (BSC)	
L	3.000	3.600	0.118	0.142
E2	8.400	9.000	0.331	0.354

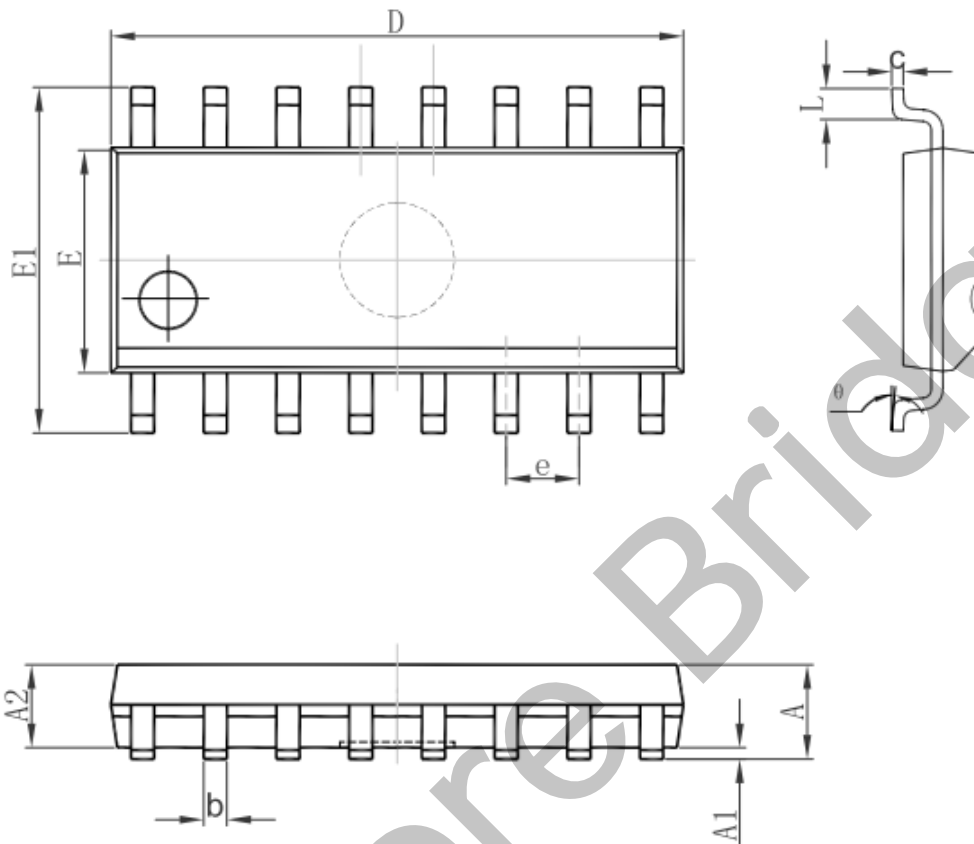
**SOP16 Outline Dimensions**

Symbol	Dimensions In Millimeters		Dimensions In Inches	
	Min	Max	Min	Max
A	1.350	1.750	0.053	0.069
A1	0.100	0.250	0.004	0.010
A2	1.350	1.550	0.053	0.061
b	0.330	0.510	0.013	0.020
c	0.170	0.250	0.007	0.010
D	9.800	10.200	0.386	0.402
E	3.800	4.000	0.150	0.157
E1	5.800	6.200	0.228	0.244
e	1.270 (BSC)		0.050 (BSC)	
L	0.400	1.270	0.016	0.050
θ	0°	8°	0°	8°

**SSOP16 Outline Dimensions**

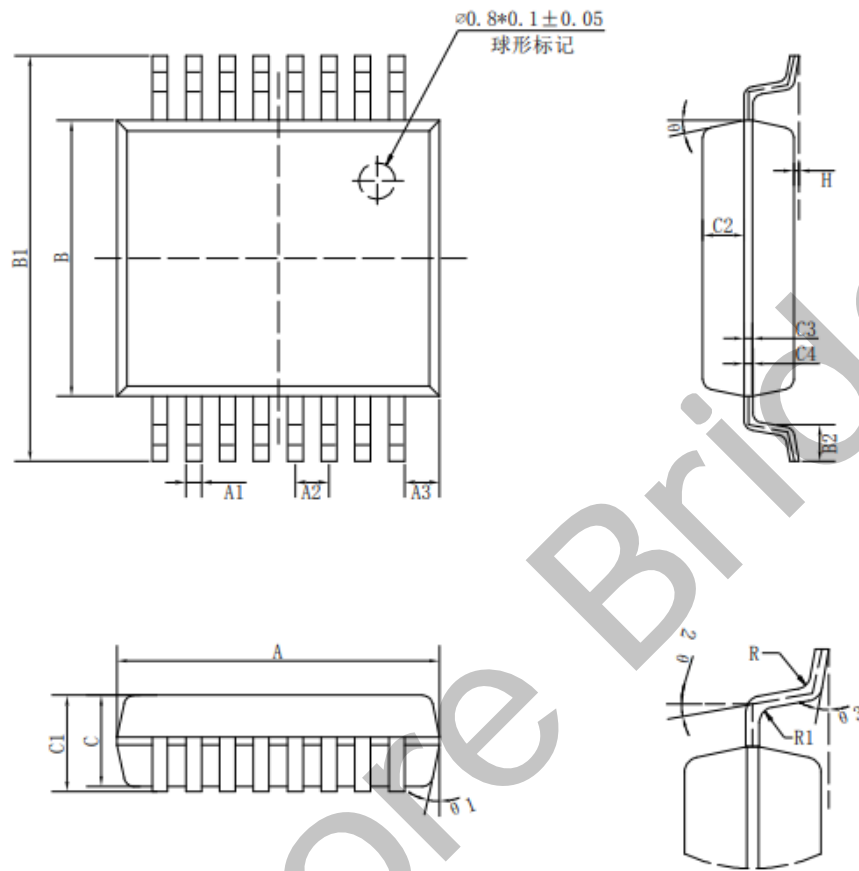

标注	尺寸	最小 (mm)	最大 (mm)	标注	尺寸	最小 (mm)	最大 (mm)
A		6.15	6.25	C3			0.152
A1		0.30TYP		C4			0.172
A2		0.65TYP		H		0.05	0.15
A3		0.675TYP		$\theta$			12° TYP4
B		5.25	5.35	$\theta 1$			12° TYP4
B1		7.65	7.95	$\theta 2$			10° TYP
B2		0.60	0.80	$\theta 3$			0° ~ 8°
C		1.70	1.80	R			0.20TYP
C1		1.75	1.95	R1			0.15TYP
C2		0.799					

TSSOP16 Outline Dimensions

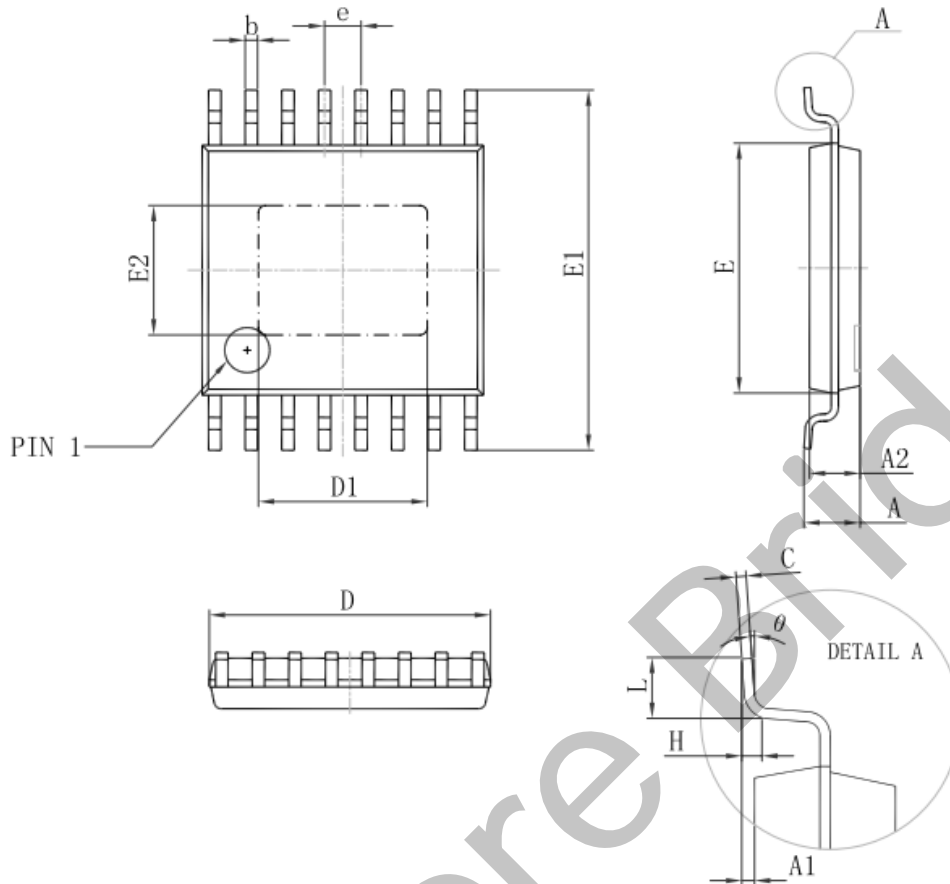

Symbol	Dimensions In Millimeters		Dimensions In Inches	
	Min	Max	Min	Max
D	4.900	5.100	0.193	0.201
D1	2.900	3.100	0.114	0.122
E	4.300	4.500	0.169	0.177
b	0.190	0.300	0.007	0.012
c	0.090	0.200	0.004	0.008
E1	6.250	6.550	0.246	0.258
E2	2.200	2.400	0.087	0.094
A		1.150		0.043
A2	0.800	1.000	0.031	0.039
A1	0.020	0.150	0.001	0.006
e	0.65 (BSC)		0.026 (BSC)	
L	0.500	0.700	0.02	0.028
H	0.25(TYP)		0.01(TYP)	
θ	1°	7°	1°	7°

Shenzhen Lianxinqiao Technology Co., Ltd  
The following statement is made:

- \* The information described herein is subject to change without notice
- \* Shenzhen Lianxinqiao Technology Co., Ltd. is not responsible for issues related to industry standards, patents or third-party rights caused by circuit or diagram descriptions. Application circuit diagrams are intended as examples of typical applications only and do not guarantee their usefulness for specialized mass production
- \* In the event of a conflict between the Products and derivatives and the Wassenaar Agreement or other international agreements, their export may require authorization from the relevant government
- \* Any reproduction or copying of the information described herein for other purposes without the permission of Shenzhen Lianxinqiao Technology Co., Ltd. is strictly prohibited
- \* The information described herein cannot be used for any human body-related equipment, such as sports equipment, medical equipment, security systems, gas equipment, or any installation on aircraft or other means of transportation without written permission
- \* Although Shenzhen Lianxinqiao Technology Co., Ltd. tries its best to improve the quality and reliability of products, the failure and failure of semiconductor products are still inevitable. Therefore, customers using this product must carry out careful safety design, including redundancy design, fire protection design, failure protection to prevent any secondary accident, fire or related damage
- \* Thank you for choosing our series of products, before using this product, please read this specification carefully, our company will not bear all losses caused by not using in accordance with the specification