

1A Standalone Linear Li-Ion Battery Charger

General Description

The UCB4056HSPF is a complete constant-current/constant-voltage linear charger for single cell lithium-ion batteries. Its ESOP8 package and low external component count make the UCB4056HSPF ideally suited for portable applications. Furthermore, the UCB4056HSPF is specifically designed to work within USB power specifications. No external sense resistor is needed, and no blocking diode is required due to the internal MOSFET architecture. Thermal feedback regulates the charge current to limit the die temperature during high power operation or high ambient temperature. The charge voltage is fixed at 4.2V, and the charge current can be programmed externally with a single resistor. The UCB4056HSPF automatically terminates the charge cycle when the charge current drops to 1C/10th the programmed value after the final float voltage is reached. When the input supply (wall adapter or USB supply) is removed, the UCB4056HSPF automatically enters a low current state, dropping the battery drain current to less than 1µA. Other features include charge current monitor, automatic recharge and a status pin to indicate charge termination and the presence of an input voltage.

Order Information

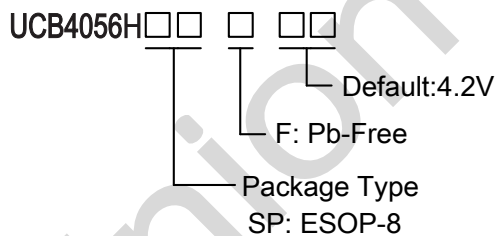

Applications

- ✧ Portable Media Players/MP3 players
- ✧ Cellular and Smart mobile phone
- ✧ PDA/DSC
- ✧ Bluetooth Applications

Features

- ◆ Protection of Reverse Connection of Battery
- ◆ Programmable Charge Current Up to 1000mA
- ◆ No MOSFET, Sense Resistor or Blocking Diode Required
- ◆ Constant-Current/Constant-Voltage Operation with Thermal Regulation to Maximize Charge Rate Without Risk of Overheating
- ◆ 1µA Supply Current in Shutdown
- ◆ Drainage Charge Current Thermal Regulation Status Outputs for LED or System Interface
- ◆ Indicates Charge and Full
- ◆ Optional Battery Temperature Monitoring Before and During Charge Automatic Sleep Mode for Low-Power
- ◆ Consumption Available in ESOP-8 Package
- ◆ RoHS Compliant and 100% Lead (Pb)-Free

Typical Application Circuit

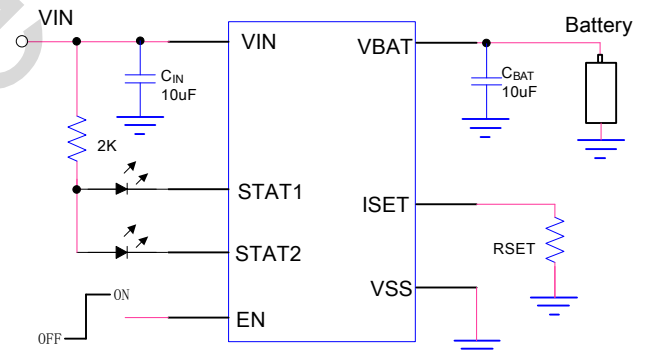

Functional Pin Description

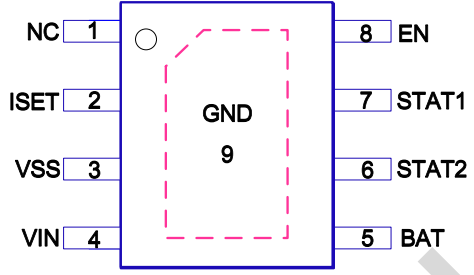
Package Type	Pin Configurations
ESOP-8	

Pin Description

PIN	PIN Number	DESCRIPTION
1	NC	No Connector.
2	ISET	Charge Current Program and Charge Current Monitor Pin. The charge current is programmed by connecting a 1% resistor, R_{ISET} , to ground. When charging in constant-current mode, this pin serves to 1V. In all modes, the voltage on this pin can be used to measure the charge current using the following formula: $I_{BAT}=1000/R_{ISET}$
3	VSS	VSS is the connection to system ground.
4	VIN	VIN is the input power source. Connect to a wall adapter.
5	BAT	BAT is the connection to the battery.
6	STAT2	Open-Drain Charge Status Output. When the battery is charging, the STAT pin could be pulled High by an external pull high resistor. When the charge cycle is completed, the pin is pulled Low by an internal N-channel MOSFET.
7	STAT1	Open-Drain Charge Status Output. When the battery is charging, the STAT pin is pulled low by an internal N-channel MOSFET. When the charge cycle is completed, the pin could be pulled High by an external pull high resistor.
8	EN	Chip enable pin. Charging when the pin is floating or connected to a high voltage. Discharge when the pin pull low.

Function Block Diagram

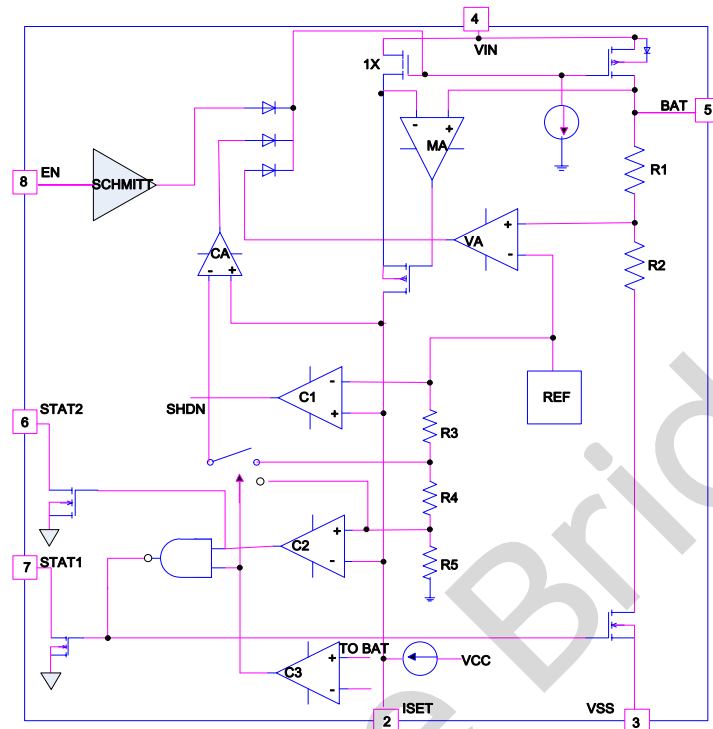

Absolute Maximum Ratings ^{Note 1}

◇ Input to GND(VIN)	-----	-0.3V to 8V
◇ BAT to GND	-----	-5V to 6V
◇ VIN to BAT	-----	8V
◇ Other Pin to GND	-----	-0.3V to 8V
◇ BAT Short-circuit Duration	-----	Continuous
◇ Storage Temperature	-----	-45°C to 165°C
◇ Operating Junction Temperature Range (TJ)	-----	-20°C to 85°C
◇ Maximum Soldering Temperature (at leads, 10 sec)	-----	260°C

Note 1. Stresses beyond those listed under “Absolute Maximum Ratings” may cause permanent damage to the device. These are stress ratings only, and functional operation of the device at these or any other conditions beyond those indicated in the operational sections of the specifications is not implied. Exposure to absolute maximum rating conditions for extended periods may affect device reliability.

Thermal Information

◇ Maximum Power Dissipation (PD,TA=25°C)	-----	2W
◇ Thermal Resistance (JA)	-----	50°C/W

ESD Susceptibility

◇ HBM(Human Body Mode)	-----	2KV
◇ MM(Machine Mode)	-----	200V

Electrical Characteristics

(The specifications which apply over the full operating temperature range, otherwise specifications are at $T_A = 25^\circ\text{C}$. $V_{IN} = 5\text{V}$, unless otherwise noted.)

SYMBOL	PARAMETER	CONDITIONS	MIN	TYP.	MAX	UNITS
V_{IN}	Adapter/USB Voltage Range		4.5	5	6.5	V
I_{CC}	Input Supply Current	Standby Mode (Charge Terminated)		50		μA
V_{FLOAT}	Regulated Output (Float) Voltage	$I_{BAT} = 40\text{mA}$	4.158	4.2	4.242	V
I_{BAT}	BAT Pin Current	$R_{ISET} = 10\text{k}$		100		mA
		$R_{ISET} = 2\text{k}$		500		
		Reverse Current, $V_{BAT} = -4.2\text{V}$		1		μA
		Standby Mode, $V_{BAT} = 4.2\text{V}$ Shutdown Mode ($R_{ISET} \text{ NC}$)		1		
I_{TRIKL}	Trickle Charge Current	$V_{BAT} < V_{TRIKL}$		10		% I_{BAT}
V_{TRIKL}	Trickle Charge Threshold Voltage	$R_{ISET} = 10\text{k}$, V_{BAT} Rising		2.9		V
V_{TR-HYS}	Trickle Charge Hysteresis Voltage	$R_{ISET} = 10\text{k}$		100		mV
V_{UV}	V_{IN} Under voltage Lockout Threshold	From V_{IN} Low to High		3.8		V
V_{UVHYS}	V_{IN} Under voltage Lockout Hysteresis			200		mV
V_{ASD}	$V_{IN} - V_{BAT}$ Lockout Threshold Voltage	V_{IN} from Low to High		150		mV
I_{TERM}	Termination Current Threshold	$R_{ISET} = 10\text{k}$		10		% I_{BAT}
		$R_{ISET} = 2\text{k}$				
V_{ISET}	ISET Pin Voltage	$R_{ISET} = 10\text{k}$, Current Mode		1.0		V
V_{STAT}	STAT Pin Output Low Voltage	$I_{STAT} = 5\text{mA}$			0.5	V
I_{STAT}	STAT1/2 Pin Weak Pull-Down Current	$I_{CHRG} = 5\text{V}$			5	μA
ΔV_{RESTAT}	Recharge Battery Threshold Voltage	$V_{FLOAT} - V_{RESTAT}$		200		mV
T_{LIM}	Junction Temperature in Constant Temperature Mode			125		$^\circ\text{C}$
R_{ON}	Power FET "ON" Resistance (Between V_{IN} and BAT)			600		$\text{m}\Omega$
V_{EN-ON}	EN Logic-High Voltage Threshold		1.4			V
V_{EN-OFF}	EN Logic-Low Voltage Threshold				0.4	V

Application Information

The UCB4056HSPF is a single cell lithium-ion battery charger using a constant-current/constant-voltage algorithm. It can deliver up to 1000mA of charge current (using a good thermal PCB layout) with a final float voltage accuracy of $\pm 1\%$ (4.2V). The UCB4056HSPF includes an internal P-channel power MOSFET and thermal regulation circuitry. No blocking diode or external current sense resistor is required; thus, the basic charger circuit requires only two external components.

Furthermore, the UCB4056HSPF is capable of operating from a USB power source.

Normal Charge Cycle

A charge cycle begins when the voltage at the VIN pin rises above the UVLO threshold level and a 1% ISET ram resistor is connected from the ISET pin to ground or when a battery is connected to the charger output. If the BAT pin is less than 3V, the charger enters trickle charge mode. In this mode, the UCB4056HSPF supplies approximately 1/10 of the ISET rammed value current to bring the battery voltage up to a safe level for full current charging.

When the BAT pin voltage rises above 3V, the charger enters constant-current mode, where the ISET rammed charge current is supplied to the battery. When the BAT pin approaches the final float voltage, the UCB4056HSPF enters constant-voltage mode and the charge current begins to decrease. When the charge current drops to 1/10 of the ISET rammed value, the charge cycle ends.

ISET ramming Charge Current

The charge current is ISET rammed using a single resistor from the ISET pin to ground. The battery charge current is 1000 the current out of the ISET pin. The ISET ram resistor and the charge current are calculated using the following equations:

$$R_{SET} = 1000V / I_{BAT}, I_{BAT} = 1000V / R_{SET}$$

The charge current out of the BAT pin can be determined at any time by monitoring the ISET pin voltage using the following equation:

$$I_{BAT} = V_{SET} \times 1000 / R_{SET}(4056)$$

Automatic Recharge

Once the charge cycle is terminated, the UCB4056HSPF continuously monitors the voltage on the BAT pin using a comparator with a 2ms filter time. A charge cycle restarts when the battery voltage falls below 4.0V (which corresponds to approximately 80% to 90% battery capacity). This ensures that the battery is kept at or near a fully charged condition and eliminates the need for periodic charge cycle initiations. CHRG output enters a strong pull-down state during recharge cycles.

Charge Status Indicator (STAT)

The charge status output has two different states: strong pull-down (~5mA) and high impedance. The strong pull-down state indicates that the UCB4056HSPF is in a charge cycle. High impedance indicates that the charge cycle complete or the UCB4056HSPF is in under voltage lockout mode: either V_{IN} is less than 150mV above the BAT pin voltage or insufficient voltage is applied to the VIN pin. A microprocessor can be used to

distinguish between these two states.		
Function	STAT1(pin7)	STAT2(pin6)
Charging	Low	High
Charge END	High	Low

Thermal Limiting

An internal thermal feedback loop reduces the ISET rammed charge current if the die temperature attempts to rise above a preset value of approximately 125°C. This feature protects the UCB4056HSPF from excessive temperature and allows the user to push the limits of the power handling capability of a given circuit board without risk of damaging the UCB4056HSPF.

The charge current can be set according to typical (not worst-case) ambient temperature with the assurance that the charger will automatically reduce the current in worst-case conditions.

Power Dissipation

The conditions that cause the UCB4056HSPF to reduce charge current through thermal feedback can be approximated by considering the power dissipated in the IC. Nearly all of this power dissipation is generated by the internal MOSFET—this is calculated to be approximately:

$$P_D = (V_{IN} - V_{BAT}) \cdot I_{BAT}$$

where P_D is the power dissipated, V_{IN} is the input supply voltage, V_{BAT} is the battery voltage and I_{BAT} is the charge current. The approximate ambient temperature at which the thermal feedback begins to protect the IC is:

$$T_A = 125^\circ\text{C} - P_D \theta_{JA}$$

$$T_A = 125^\circ\text{C} - (V_{IN} - V_{BAT}) \cdot I_{BAT} \cdot \theta_{JA}$$

Packaging Information

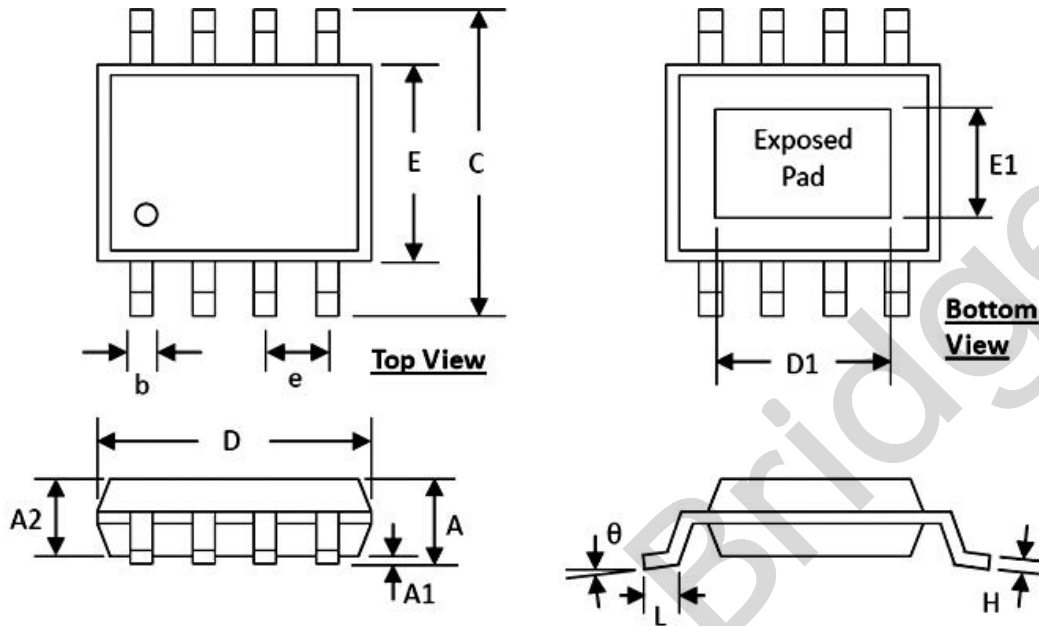

SYMBOLS	DIMENSION (MM)		DIMENSION (INCH)	
	MIN	MAX	MIN	MAX
A	1.30	1.70	0.051	0.067
A1	0.00	0.15	0.000	0.006
A2	1.25	1.52	0.049	0.060
b	0.33	0.51	0.013	0.020
C	5.80	6.20	0.228	0.244
D	4.80	5.00	0.189	0.197
D1	3.15	3.45	0.124	0.136
E	3.80	4.00	0.150	0.157
E1	2.26	2.56	0.089	0.101
e	1.27 BSC		0.050 BSC	
H	0.19	0.25	0.0075	0.0098
L	0.41	1.27	0.016	0.050
θ	0°	8°	0°	8°