

Features

- Output Current of 100mA
- Thermal Overload Protection
- Short Circuit Protection
- Output transistor safe area protection
- No external components
- Package: SOT89-3 and TO92
- Output voltage accuracy: tolerance $\pm 5\%$

General Description

78L05 is three-terminal positive regulators. One of these regulators can deliver up to 100 mA of output current. The internal limiting and thermal-shutdown features of the regulator make them essentially immune to overload. When used as a

replacement for a zener diode-resistor combination, an effective improvement in output impedance can be obtained, together with lower quiescent current.

Pin Configuration

SOT89 (Top view)

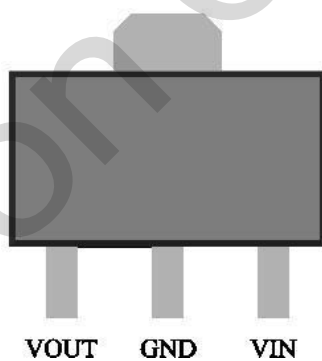

TO92 (Front view)

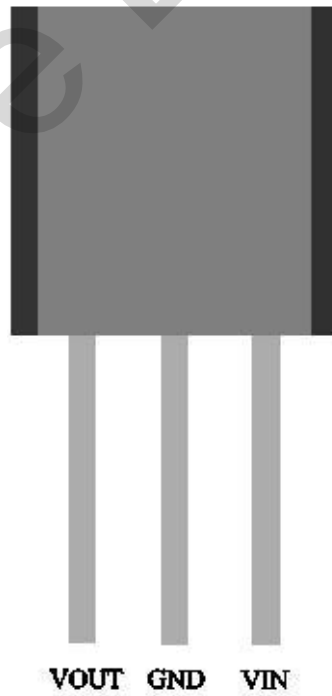

Selection Table

Part No.	Output Voltage	Package	Marking
78L05	5.0V	TO92 SOT89	
78L06	6.0V		
78L08	8.0V		
78L09	9.0V		
78L12	12V		

Block Diagram

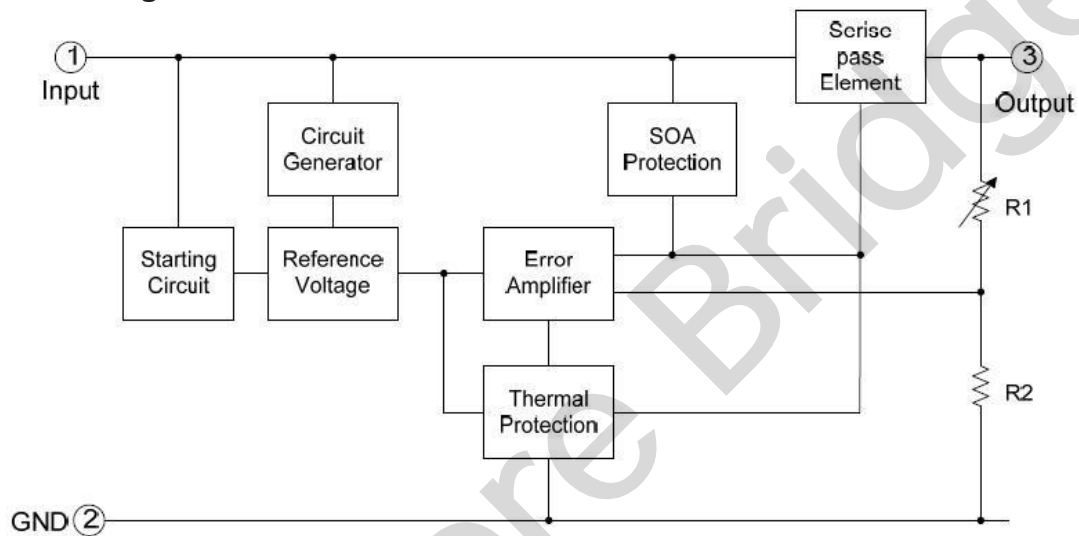

Absolute Maximum Ratings (Ta=25°C)

Parameter	Rating	Unit
Input supply voltage: VIN	30	V
MAX. Output current: Iout	100	mA
MAX Power: Pmax	0.5	W
Maximum junction temperature: Tj	-25~125	°C
Storage temperature: Tstr	-55~125	°C
Soldering temperature and time	+260(Recommended 10S)	°C

Note: The absolute maximum ratings are rated values exceeding which the product could suffer physical damage. These values must therefore not be exceeded under any conditions.

Electrical Characteristics

(C_{in}=0.33uF, C_o=0.1uF, 0 ≤ T_j ≤ 125 °C, unless otherwise noted)

Parameter	Symbol	Conditions	Min.	Typ.	Max.	Unit
Output Voltage	V _{out}	I _o =40mA, V _{IN} =10V	0.964V _{out}	V _{out}	1.036V _{out}	V
		I _o =1mA~40mA V _{IN} =7V~18V	0.96V _{out}	V _{out}	1.04V _{out}	
		I _o =1mA~10mA V _{IN} =10V	0.95V _{out}	V _{out}	1.05V _{out}	
Line Regulation	LNR	V _{IN} =7V~18V, I _o =20mA	-150	-	150	mV
		V _{IN} =8V~18V, I _o =20mA	-100	-	100	
Load Regulation	LDR	V _{IN} =10V, I _o =1mA~100mA	-100	-	100	mV
		V _{IN} =10V, I _o =1mA~40mA	-30	-	30	
Dropout Voltage	V _{DIF}	T _j =25 °C, I _o =100mA	-	2	-	V
Output noise Voltage	V _N	F=10Hz to 100KHz	-	40	-	uV/V _o
Ripple Rejection	PSRR	T _j =25 °C, f=120Hz, I _o =40mA, V _{IN} =8V~20V	-	80	-	dB
Quiescent Current	I _q	V _{IN} =10V, I _O UT=40mA	-	-	5.5	mA
Quiescent Current Change	ΔI _q	V _{IN} =8V~18V, I _o =20mA	-1.5	-	1.5	mA
		V _{IN} =10V, I _O UT=1mA~40mA,	-0.1	-	0.1	

LNR: Line Regulation. The change in output voltage for a change in the input voltage. The measurement is made under conditions of low dissipation or by using pulse techniques such that the average chip temperature is not significantly affected.

LDR: Load Regulation. The change in output voltage for a change in load current at constant chip temperature.

Typical Performance Characteristics

Output Voltage vs. Input voltage

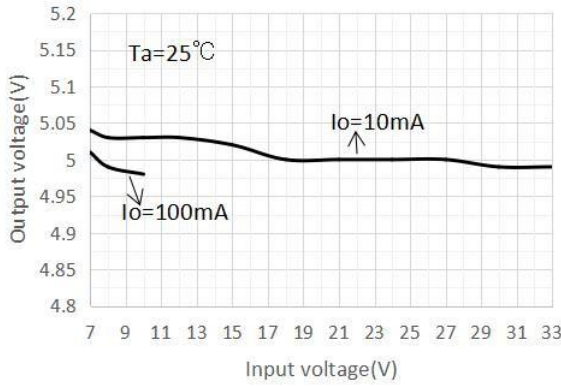

Output Voltage vs. Load

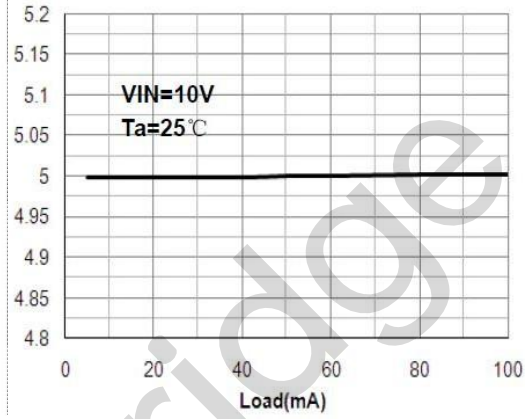

Output voltage vs. Temperature

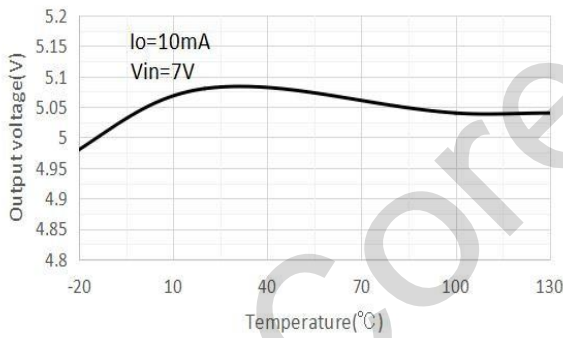

Dropout Voltage vs. Load

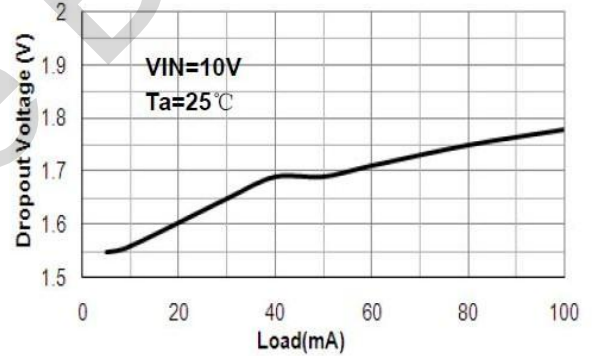

Quiescent current vs. Input voltage

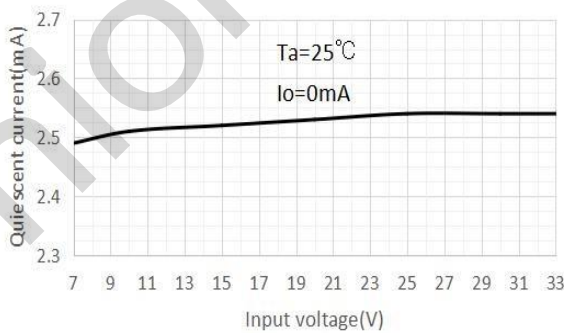

Quiescent Current vs. Load

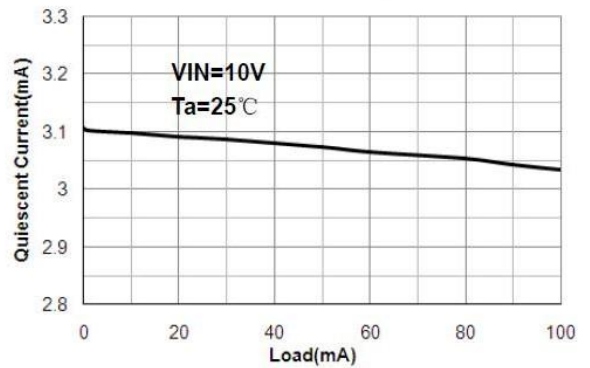

Operation Description

78L05 is designed with Thermal Overload Protection that shuts down the circuit when subjected to an excessive power overload condition, Internal Short Circuit Protection that limits the maximum current the circuit will pass, and Output Transistor Safe-Area Compensation that reduces the output short circuit current as the voltage across the pass transistor is increased.

In many low current applications, compensation capacitors are not required. However, it is recommended that the regulator input be bypassed with a capacitor if the regulator is connected to the power supply filter with long wire lengths, or if the output load capacitance is large. An input bypass capacitor should be selected to provide good high frequency characteristics to insure stable operation under all load conditions. A 0.33μF or larger tantalum, mylar, or other capacitor having low internal impedance at high frequencies should be chosen. The bypass capacitor should be mounted with the shortest possible leads directly across the regulator's input terminals. Normally good construction techniques should be used to minimize ground loops and lead resistance drops since the regulator has no external sense lead.

Typical Application

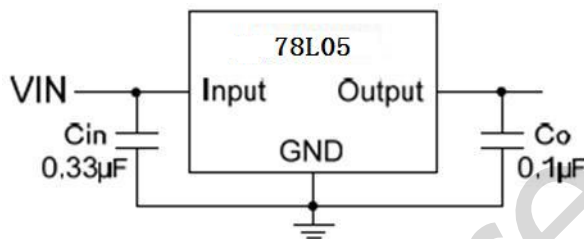

Fig.1 Fixed Output Regulator

A common ground is required between the input and the output voltages. The input voltage must remain typically 2.0 V above the output voltage even during the low point on the input ripple voltage.

- Cin is required if regulator is located an appreciable distance from power supply filter.
- Co is not needed for stability; however, it does improve transient response.

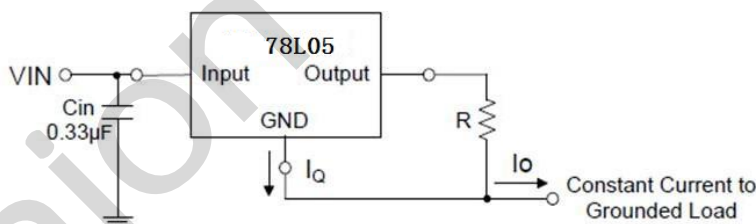

Fig.2 Constant Current Regulator

The 78LXX regulator can also be used as a current source when connected as Fig.2. In order to minimize dissipation the 78LXX is chosen in this application. Resistor R determines the current as

follows:

$$I_o = \frac{5V}{R} + I_q$$

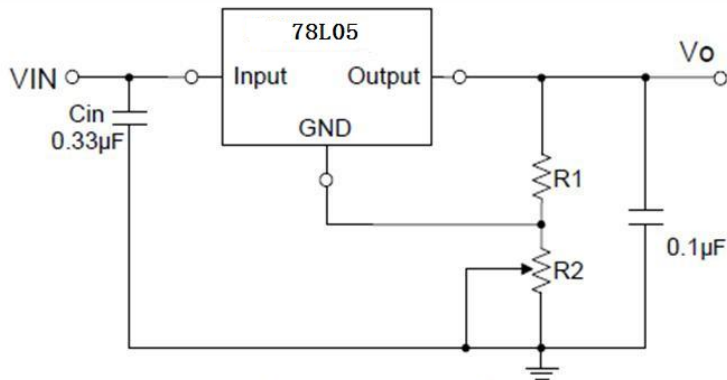
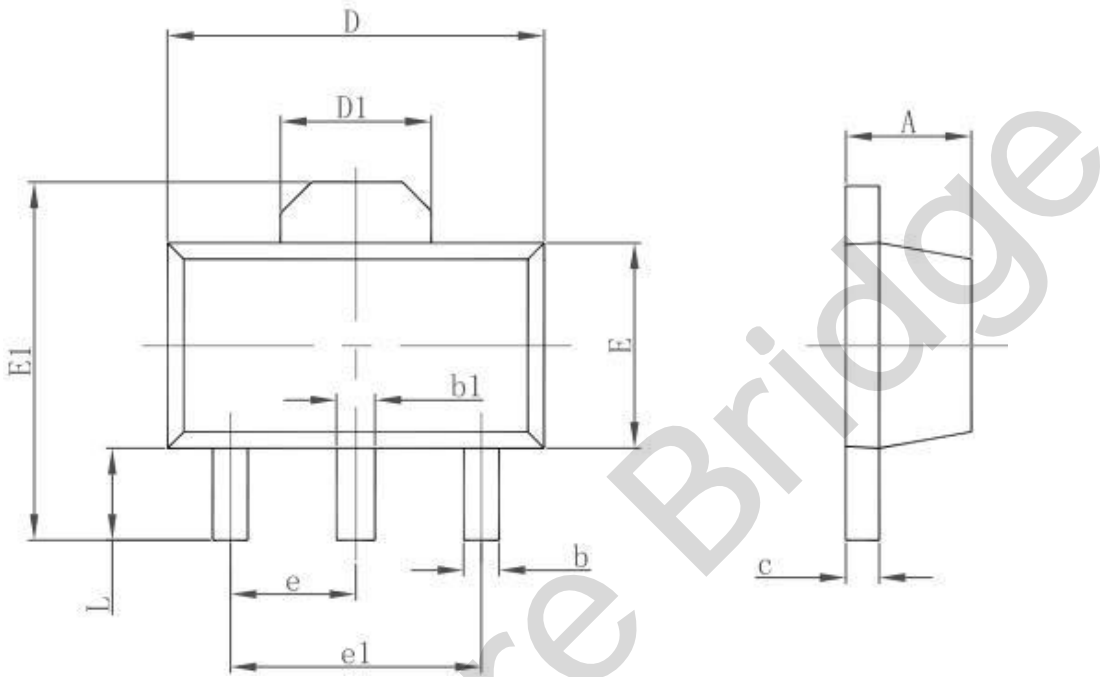

Fig.3 Adjustable Output Regulator

$$V_o = 5V + (5V/R_1 + I_Q) \cdot R_2$$

$$5V/R_1 > 3 \cdot I_Q$$

Package Information
3-pin SOT89 Outline Dimensions



Symbol	Dimensions In Millimeters		Dimensions In Inches	
	Min.	Max.	Min.	Max.
A	1.400	1.600	0.055	0.063
b	0.320	0.520	0.013	0.020
b1	0.400	0.580	0.016	0.023
c	0.350	0.440	0.014	0.017
D	4.400	4.600	0.173	0.181
D1	1.550 REF.		0.061 REF.	
E	2.300	2.600	0.091	0.102
E1	3.940	4.250	0.155	0.167
e	1.500 TYP.		0.060 TYP.	
e1	3.000 TYP.		0.118 TYP.	
L	0.900	1.200	0.035	0.047

3-pin TO92 Outline Dimensions

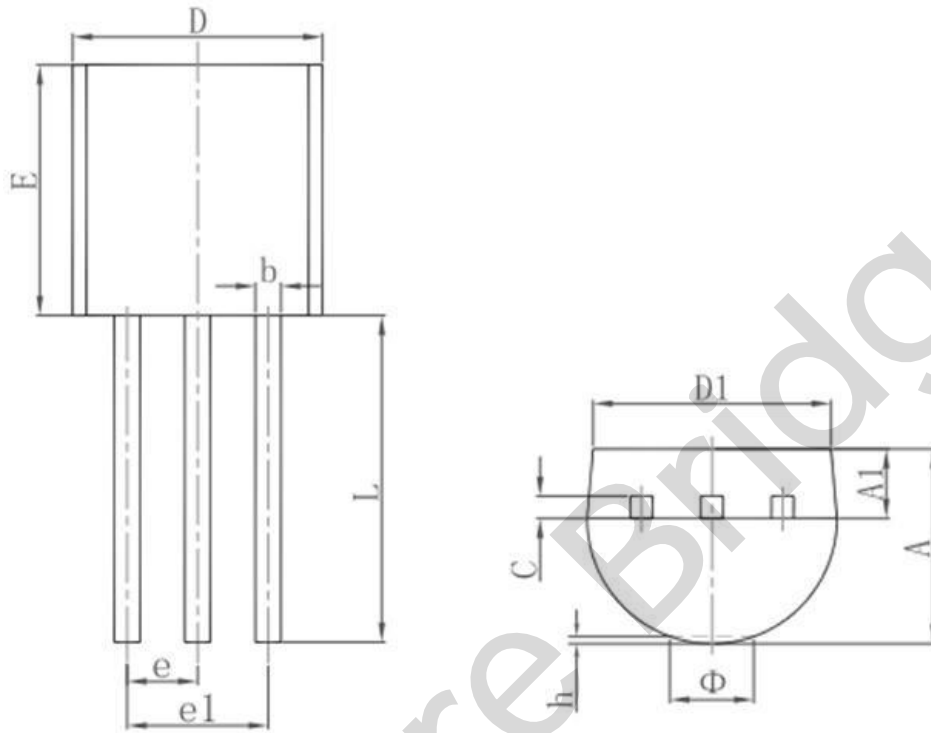

Symbol	Dimensions In Millimeters		Dimensions In Inches	
	Min.	Max.	Min.	Max.
A	3.300	3.700	0.130	0.146
A1	1.100	1.400	0.043	0.055
b	0.380	0.550	0.015	0.022
c	0.360	0.510	0.014	0.020
D	4.300	4.700	0.169	0.185
D1	3.430		0.135	
E	4.300	4.700	0.169	0.185
e	1.270 TYP.		0.050 TYP.	
e1	2.440	2.640	0.096	0.104
L	14.100	14.500	0.555	0.571
Φ		1.600		0.063
h	0.000	0.380	0.000	0.015